



Modified



FUN WITH English



Pupil's Book

Grade
2B



Modified

FUN WITH English

Pupil's Book Grade 2B



Julia Allen - Margaret Iggulden



All rights reserved; no part of this publication may be reproduced, stored in a retrieval system, or transmitted in any form or by any means, electronic, mechanical, photocopying, recording, or otherwise, without the prior written permission of the Publishers.

Egyptian International Publishing Company - Longman,

10a Hussein Wassef Street,
Messaha Square,
Dokki,
Cairo,
Arab Republic of Egypt

*The Longman imprint is the property of Pearson Education
being used under license from Pearson Education.*

Acknowledgements:

Additional material provided by Matthew Hancock

First edition 2003

Second edition 2006

Third edition 2008

Fourth edition 2015 / 2016

Fifth edition 2017 / 2018

Reprinted 2018 / 2019

Printed in Kuwait by:

AlResala Printing Press Co.

The publisher wishes to thank the Evaluation
Committee of Kuwait Ministry of Education:

Professor Najat Al Mutawa, Kuwait University;
Professor M. Rifqy Eassa, Educational Holding Group;
Dr. Yusr Al-Madani, Kuwait University;
Dr. Badria A. Al-Haji, College of Basic Education (PAAET);
Mrs. Sakina A. Hussain, Senior Supervisor, MoE;
Mr. M. Naguib Ali, Supervisor, MoE;
Mr. Sayed Ghareeb Abdel Rahman, Supervisor, MoE;
Mr. Alhu Hamu Sharaha, Senior Teacher, MoE;
Mrs. Khawla Al Refae, Senior Teacher, MoE;
Ms. Aisha Al-Awadhi, Assistant Principal, MoE.

The publisher wishes to thank the Evaluation
Committee of Kuwait Ministry of Education:

Mrs. Nouria Al Sedra, ELT Senior Supervisor, MoE;
Mr. Mohamed Nagib Ali, ELT Supervisor, MoE;
Mr. Sayed Ghareeb AbdelRahman, ELT Supervisor, MoE;
Mr. Mahmoud Hammouda, ELT Supervisor, MoE;
Mrs. Khawla Al Refae, ELT Supervisor, MoE;
Mr. Mohamed Sallam, ELT Supervisor, MoE;
Mrs. Sherifah Al Sayegh, ELT Head of Department, MoE;
Mrs. Rehab Mohamed Nadim, ELT Head of Department, MoE;
Mrs. Rehab Ahmed Emam, ELT Head of Department, MoE;
Mrs. Hessa Al-Banwan, ELT Head of Department, MoE;
Mrs. Noura Al-Mokmash Al-Azmi, ELT Head of Department, MoE;
Mrs. Azza Mohammad Awad, ELT Head of Department, MoE;
Mrs. Nevine Abdul Majeed Omar, ELT Head of Department, MoE.

The publisher also wishes to thank the Committee of updating
curricula and English language books for elementary school: 2013

Mrs. Nouria AL Sedra, ELT Senior Supervisor, MOE;
Mr. Mohamed Nagib Ali, ELT Senior Supervisor, MOE ;
Mrs. Amira Abdelaziz Haidar AL Qattan, ELT Supervisor, MOE ;
Mrs. Fatma Ameen Mohammed, ELT Supervisor, MOE;
Mrs. Sherifah AL Sayegh, ELT Supervisor, MOE;
Mrs. Mariam Emadaldeen Abdulrahman, ELT Head of Department, MOE;
Mrs. Rania Nohman AL Omani, Head of Department, MOE;
Mrs. Muneera Sabir Mohammed Al Yaqobi, Teacher, MOE;
Mrs. Lulwa Waleed AL Ameer, teacher, MOE;
Mrs. Reham Abdullah Bastaki, teacher, MOE;
Mrs. Farah Jassim Al Khawajah, teacher, MOE;

A Special mention for their valued contribution (2016 / 2017)

Mrs. Amira Abdelaziz Haider Al Qattan, ELT Supervisor, MOE;
Mrs. Fatma Ameen Mohammed, ELT Supervisor, MOE;
Mrs. Mariam Emadaldeen Abdulrahman, ELT HOD, MOE;
Mrs. Muneera Sabir Mohammed Al Yaqobi, Teacher, MOE;
Mrs. Reham Abdullah Bastaki, Teacher, MOE;
Mrs. Farah Jassim Al Khuwajah, Teacher, MOE;



PDF Book



Share on evaluation



بِسْمِ اللَّهِ الرَّحْمَنِ الرَّحِيمِ

مدرستي
الكويتية
school-kw.com





H.H. Sheikh Sabah Al-Ahmad Al-Jaber Al-Sabah
The Amir of the State of Kuwait

مدرستي
الكويتية
school-kw.com





H.H. Sheikh Nawaf Al-Ahmad Al-Jaber Al-Sabah
The Crown Prince of the State of Kuwait





Content

Unit 6 Let's go shopping page 17

Unit 7 At school page 25

Unit 8 I like animals page 33

Unit 9 My neighbourhood page 41

Unit 10 Kuwait in the past page 49

Pictionary page 58

Songs page 63

E-learning page 67

مدرستي
الكويتية
school-kw.com





Synopsis

Unit title	Specific Comprehences to be developed		Language functions (Speech acts)	Language structure	
6. Let's go shopping	L	1.1	<ul style="list-style-type: none"> • Making suggestions. • Describing objects. • Asking and answering questions about shopping / places / food. • Talking about one's shopping list. 	Phonics	/ oo / / wh /
	S	2.1 2.2		Vocabulary related to:	<ul style="list-style-type: none"> • Places • Food items • Adjectives of size
	R	3.2 3.3		Grammar	<ul style="list-style-type: none"> • Present simple • Expression possessions (have got)
	W	4.1			

Unit title	Specific Comprehences to be developed		Language functions (Speech acts)	Language structure	
7. At school	L	1.3	<ul style="list-style-type: none"> • Asking and answering questions about school. • Describing school rooms. Counting by tens.. 	Phonics	/ bl / / br /
	S	2.1 2.3		Vocabulary related to:	<ul style="list-style-type: none"> • School objects • Numbers (10s) • School rooms • Colours
	R	3.2 3.4		Grammar	<ul style="list-style-type: none"> • Present simple • Past simple
	W	4.1 4.3			

Unit title	Specific Comprehences to be developed		Language functions (Speech acts)	Language structure	
8. I like animals	L	1.1 1.2.2	<ul style="list-style-type: none"> • Asking and answering questions about animals. • Asking for and giving information. • Describing actions. 	Phonics	/ ar / / ir /
	S	2.2 2.3		Vocabulary related to:	<ul style="list-style-type: none"> • Animals • Colours
	R	3.2 3.4		Grammar	<ul style="list-style-type: none"> • Present simple • Present progressive
	W	4.1 4.3			



Unit title	Specific Comprehences to be developed		Language functions (Speech acts)	Language structure	
9. My neighbourhood	L	1.3	<ul style="list-style-type: none"> Asking for and giving information. Describing places. Prepositions. 	Phonics	/ck / / un /
	S	2.1 2.4		Vocabulary	<ul style="list-style-type: none"> Places Neighbourhood
	R	3.1 3.3		Grammar	<ul style="list-style-type: none"> Present simple Wh.. question Prepositions at place
	W	4.1 4.3			

















Unit title	Specific Comprehences to be developed		Language functions (Speech acts)	Language structure	
10. Kuwait in the past	L	1.2.2	<ul style="list-style-type: none"> Talking about the past. Asking and answering questions about past events. 	Phonics	/ ph / / or /
	S	2.1 2.4		Vocabulary	• Kuwait in the past
	R	3.1 3.3		Grammar	<ul style="list-style-type: none"> Past simple Wh questions
	W	4.1 4.2			



Icon Guide

No.	Icon	Description	No.	Icon	Description
1		Look	11		Join and colour
2		Listen	12		Critical thinking
3		Say	13		Self assessment
4		Answer	14		Moral value
5		Ask and answer	15		Project
6		Look and say	16		Odd one out
7		Trace	17		Match
8		Trace and copy	18		Count
9		Colour	19		Action
10		Write	20		Point



No.	Icon	Description	No.	Icon	Description
17		Draw	25		Cut and paste
18		Play	26		Tell
19		Circle	27		Tick
20		Number	28		Read
21		Talk	29		Connector
22		Summative assessment	30		Formative
23		Formative assessment	31		Order
24		Find	32		Extension



Let's meet our characters



Salem



Dana



DEE



Haya



Ali



Unit

6

Let's go shopping

We will learn:

- Making suggestions.
- Describing objects.
- Asking and answering questions about shopping.

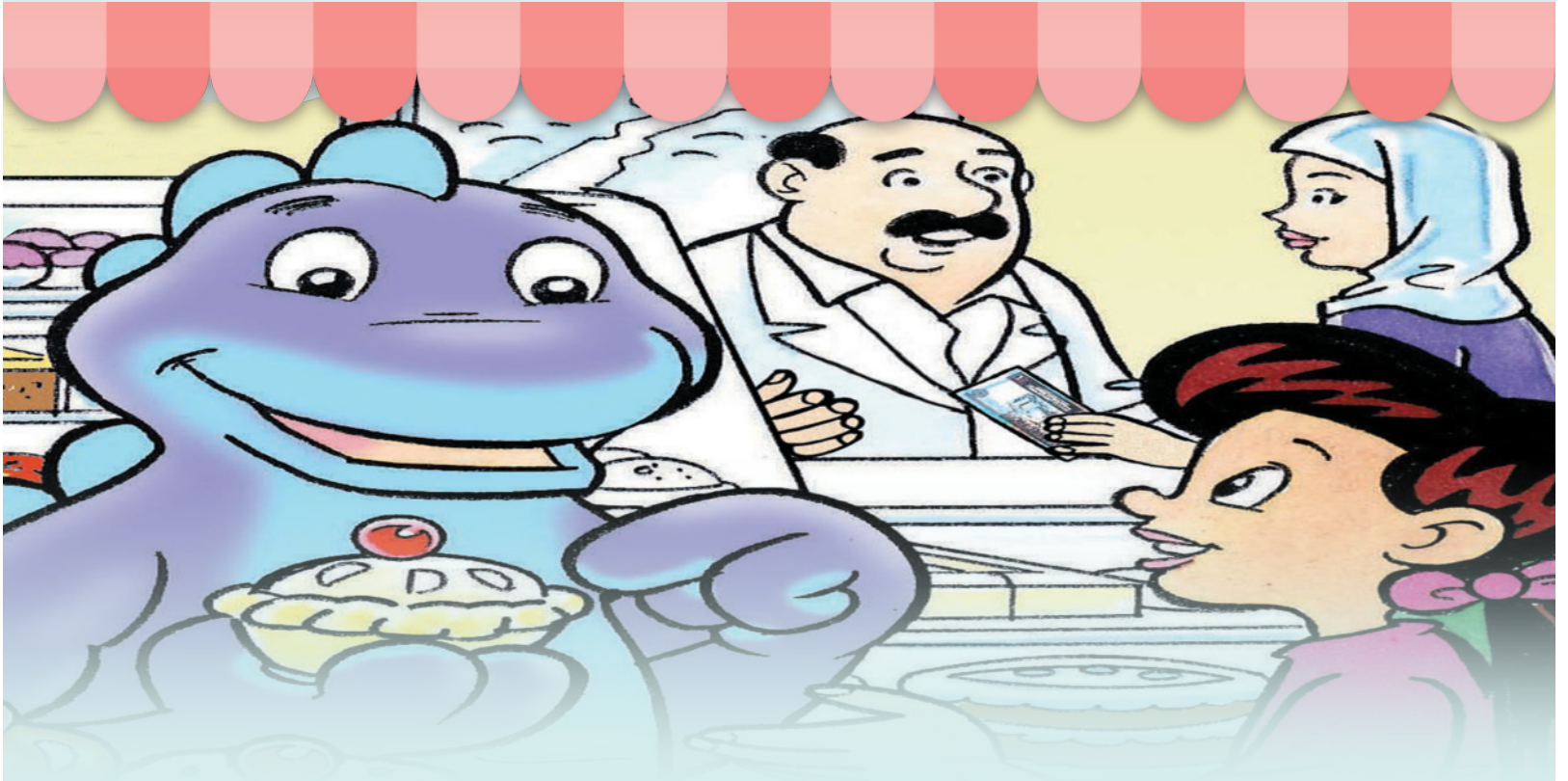

Dee goes shopping**Listen and read**

Haya wants to eat a pie. She asks Mum, "Have we got any pies?" Mum says, "No, we haven't." Dee says "Let's go to the bakery. They have got pies and cakes! I want a cake." Mum says "Ok. Let's go." At the bakery, Mum buys an apple pie and a cake. Dee and Haya are very happy.



What do you buy at the bakery?

I buy a cake and pie



Copy



I got a tasty pie at the bakery.



Look, answer and colour

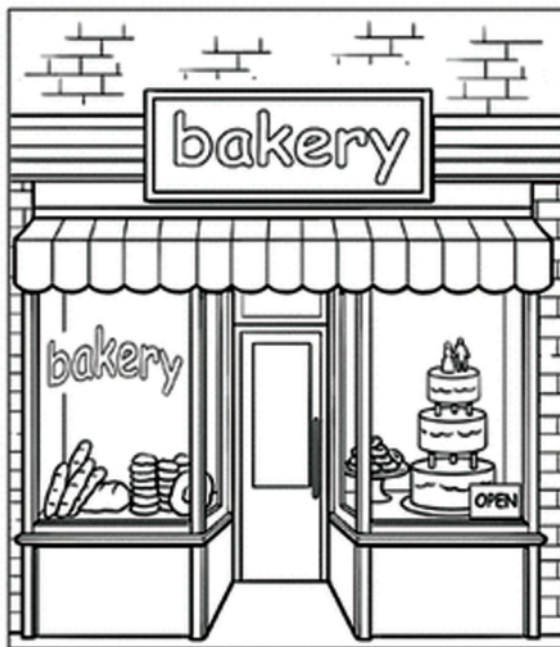

Why do we go to the bakery?

We go to the bakery to buy bread , cake and pie



Let's talk about our visit to the bookshop



Look and read.



I took a good book to learn how to cook.



What do you buy at the bookshop?



Discuss and answer the following questions



1 - When do you go to the bookshop?

I go to the bookshop every Saturday

2 - What time do you go?

I go at 4 pm

3 - What books do you buy?

I buy story books



Circle the sound "oo"





Have we got ...?



Look and read



He watches the **white whales** **while** he's sitting on his **wheel** chair.



How can?



Write your shopping list



Chicken

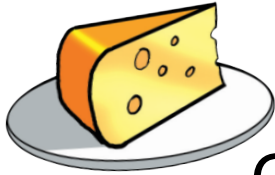

Cheese



Milk

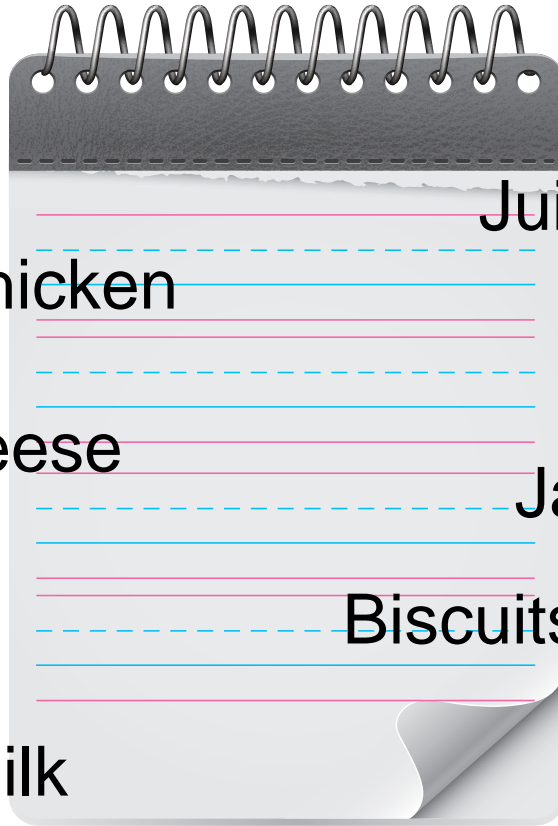

Juice



Jam

Biscuits



Write the missing words



A car has 4 wheels.



Mothers cook nice food.



She's got white shoes.

I feel







Unit

7

At school

We will learn:

- Asking and answering questions about school.
- Describing objects.
- Counting by tens.
- Asking for and giving information.



Unit
7

At school

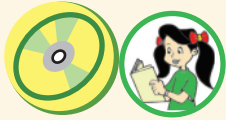

Listen and read

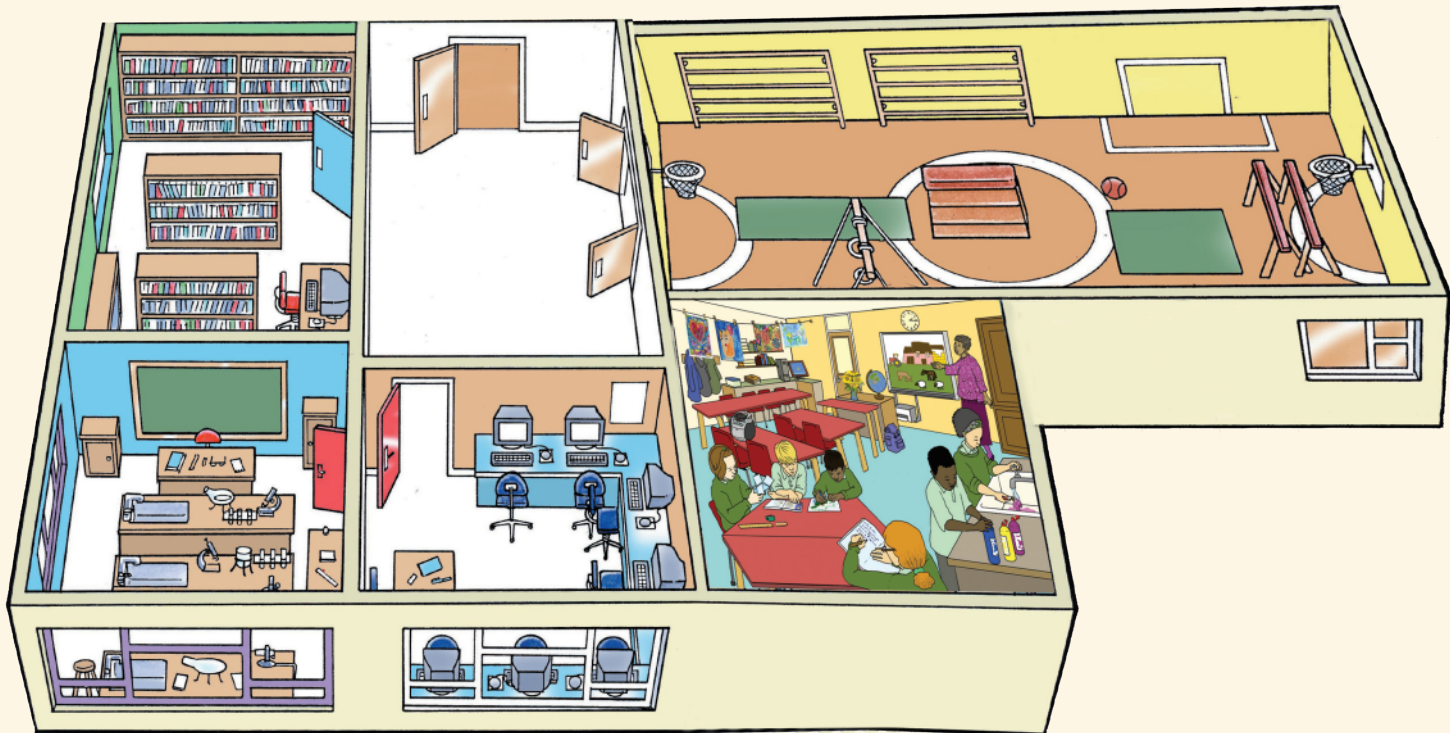

Listen and read

This is my school. We have a science lab, an art class and a computer lab. Ali's favourite subjects is P.E. He plays basketball every Monday. Haya likes math. She likes counting. My school is cool.



What is your favourite class at school?



Read and colour

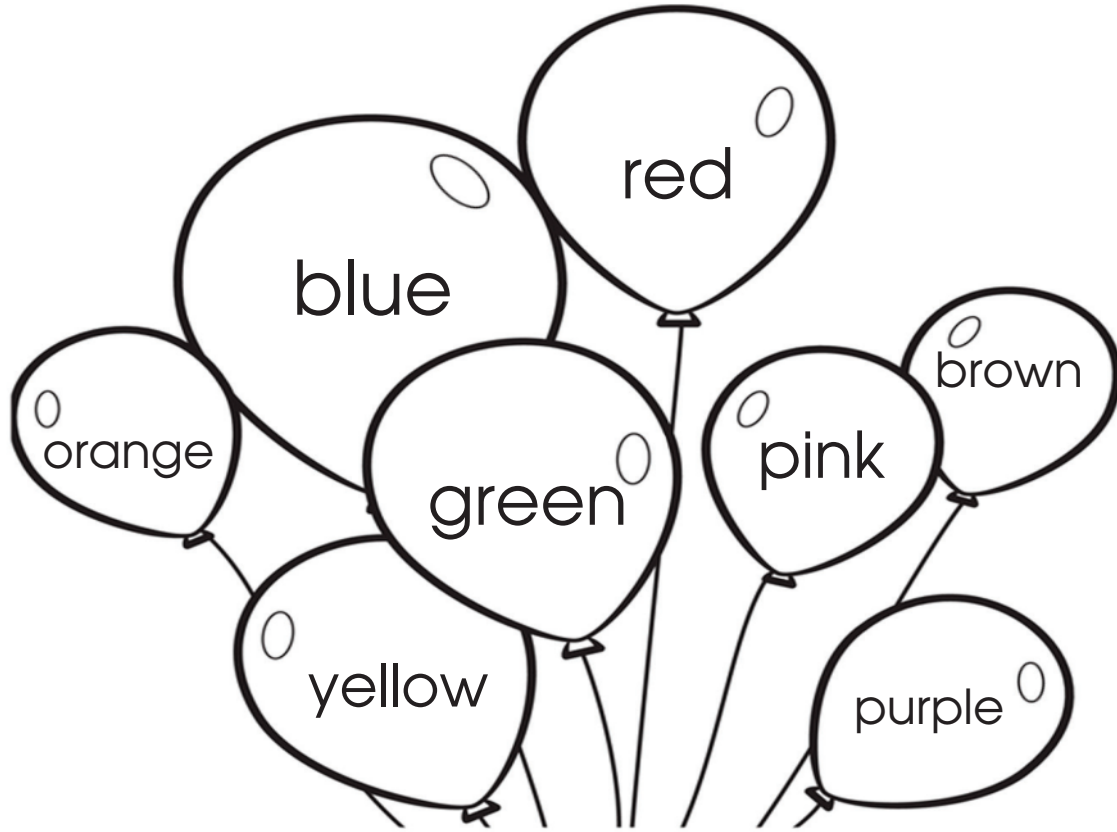

FA Tell your friends how to keep school clean
We put every trash in its trash box





Lets count by tens

10
ten



20
twenty



30
thirty



40
forty



50
fifty



60
sixty



70
seventy



80
eighty



90
ninety



100
one hundred



Look and read

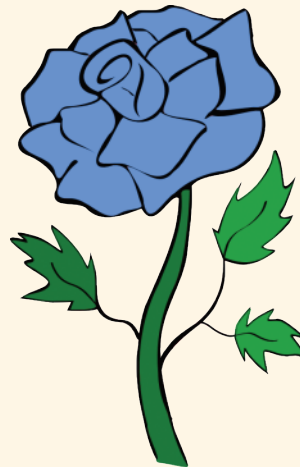
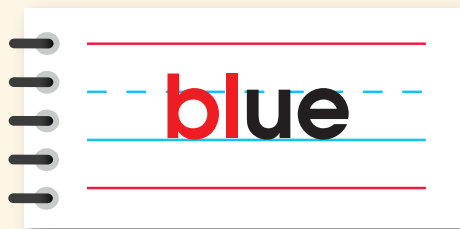

The **blue** flower **blossoms** when wind **blows**



How many classrooms are there in your school?

There are 20 classrooms in my school



FA

How much does it cost?



=



30



=



60



=

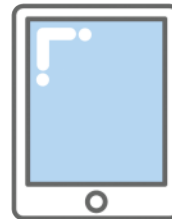

80



Copy and punctuate

he's got a ruler.





Ask and answer



Look and read



My **brother** **broke** my mother's **brown** **broom**



How do you keep your school clean?



Complete

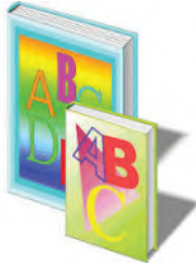
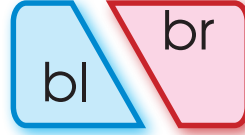
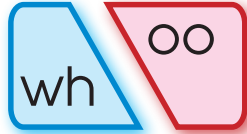

book

brown

black

wheels



Where can you...?



I feel





Unit

8

I like animals

We will learn:

- Asking and answering questions about animals.
- Asking for and giving information.
- Describing animals.
- Describing actions.



I like animals

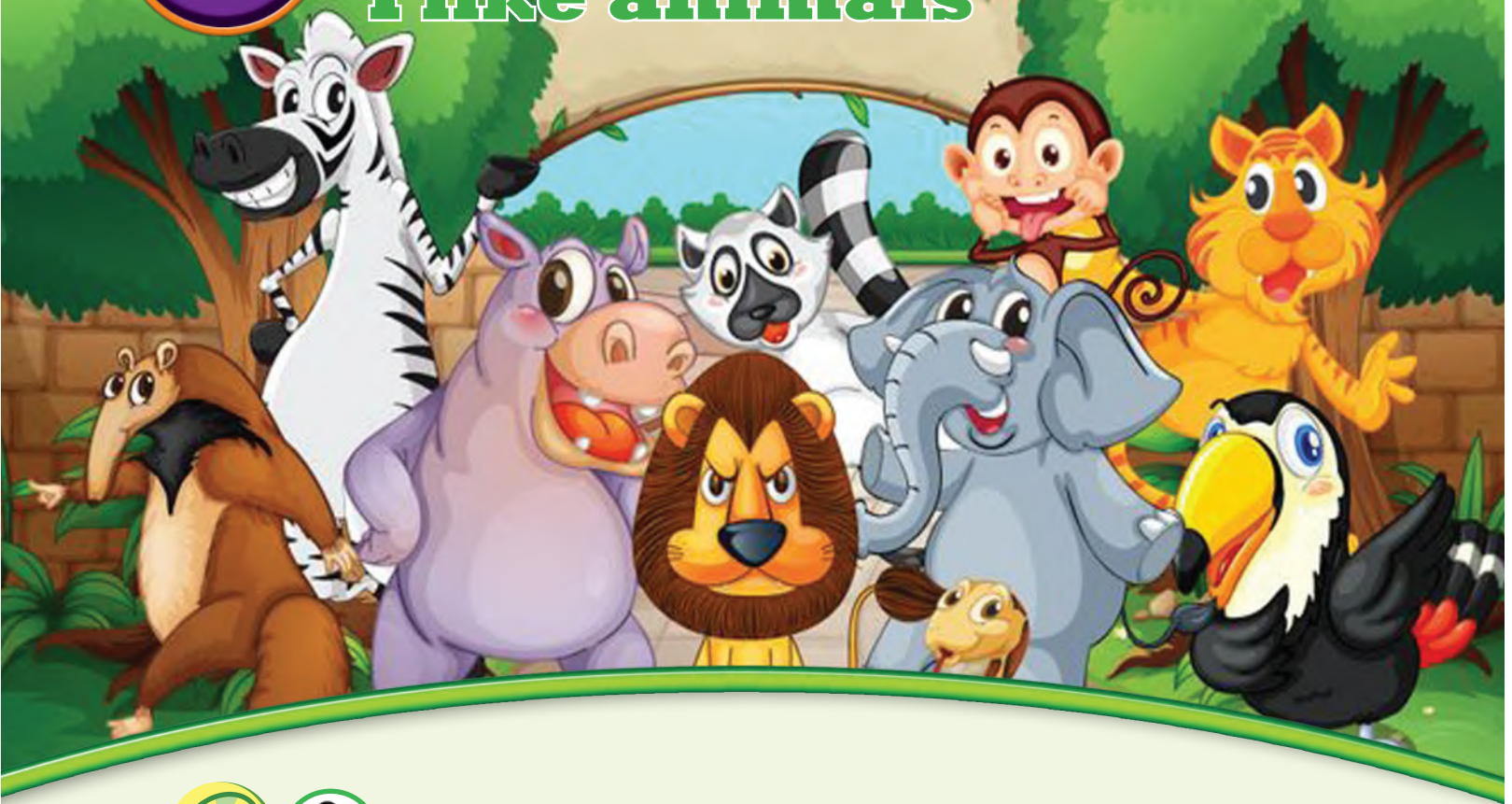

Listen and read

Going to the zoo can be lots of fun. I can see lots of animals there. I like watching the monkeys climbing the trees, the lions eating meat, tigers sleeping. I like watching the tall giraffes eating leaves from the tree. I can go to the zoo with my family to have fun.



What is your favourite animal? why?

My favorite animal is the monkey because its
funny



Read, complete and match

run - fly - swim - climb

1 - Birds

Fly

2 - Tigers

Run

3 - Monkey

Climb

4 - Ducks

Swim

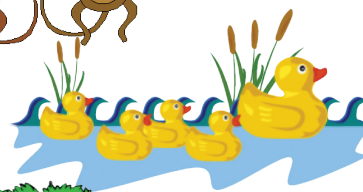

Guess and write the animal

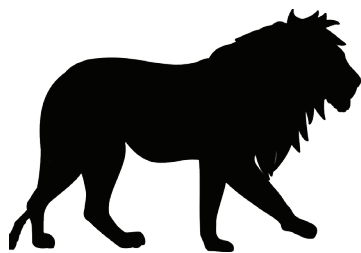

Lion

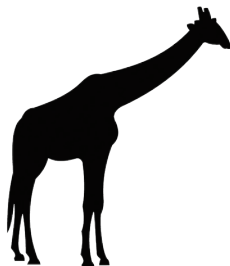

giraffe



camel



Describe zoo animals



Look and read.

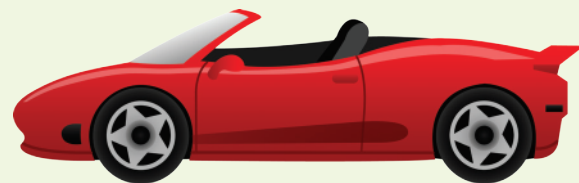
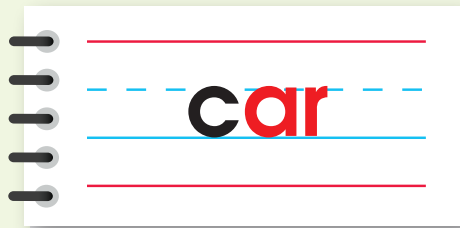

We went **far** by a smart **car** to my uncle's **farm**



What animals do you see in the zoo?



I see the lion , monkey , giraffe and zebra.....



Read, circle and describe the animals

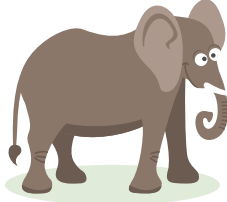

- yellow
- long legs
- big ears



- zoo
- farm
- beach



- milk
- grass
- meat



- zoo
- fly
- climb



Write sentences to describe the pictures



The elephant has big ears

I see a yellow giraffe in the zoo



The giraffe has long legs

The zebra eats grass

Monkeys climb the trees



Let's talk about animals



Look and read.

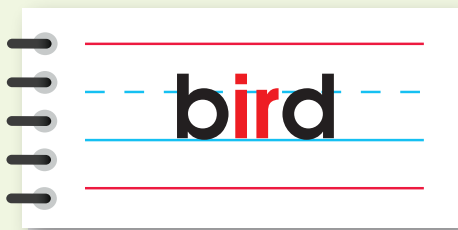

There is a yellow **bird** on the **girl's shirt**



How can you be kind to animals?

We don't harm animals



SA

Complete the crossword

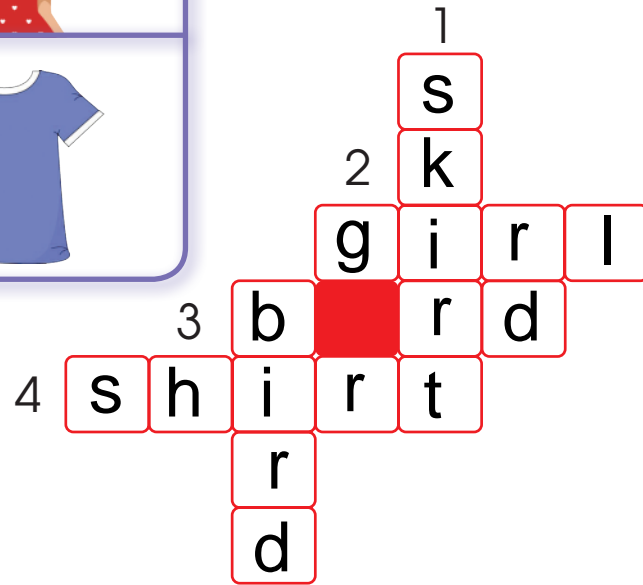

SA



Order and write

a / It's / zebra / big

it's a big zebra

tigers/are/They/yellow

They are yellow tigers



I feel



Make a zoo





Unit

9

My neighbourhood

We will learn:

- Asking for and giving information.
- Describing places.
- Using prepositions of places.



Unit
9

My neighbourhood

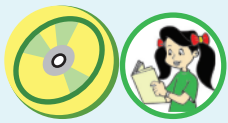

Listen and read

Fahad lives in Al-Nuzha at house number 15. He has many neighbours. They are friendly. Omar lives next to his house at number 17. Every day he goes to school with Omar. On Saturdays they play football together in the park. They have lunch in the restaurant next to their houses.



Where do you live?

I live in Kuwait



Who lives where?

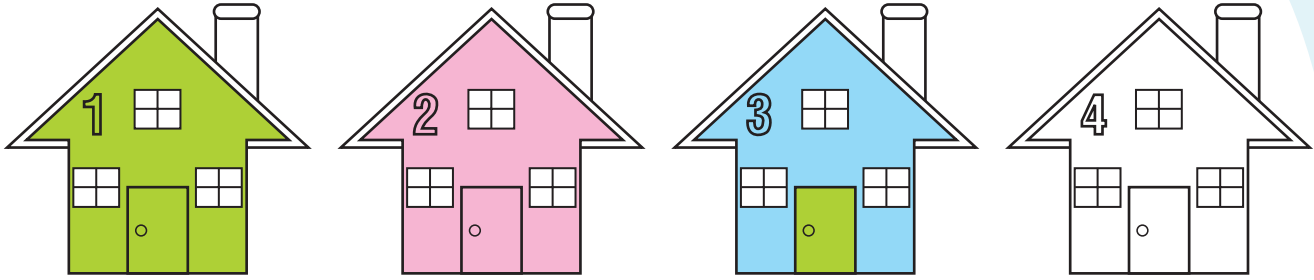

Jassim

Sara

Ali

omar

1 - Ali's house is the blue house with the green door.

2 - Sara lives next to house number 3. it's pink.

3 - Omar lives next to Ali's house at number 4.

4 - Where does jassim live? At number

1



Read and answer

Who is your neighbour?

Salim is my neighbour



Where are they? Why?



Look and read

Value
Respect and help your neighbours.



Hickory, Dickory, dock. The mouse ran up the clock



How can you help your neighbours?



i help my neighbour by money and food



Guess and write the place

I go there to buy bread.

The bakery

I go there to pray.

The mosque

I go there to buy books.

The bookshop

I go there to play with
my friends

The club



Find the differences and tell your friend

اوجد الاختلافات بين الصور واخبر زميلك





Let's ask and answer



Where do you come from?

Where do you live?

What number is your house?

I come from

I live in

I live in house number



Look and read.

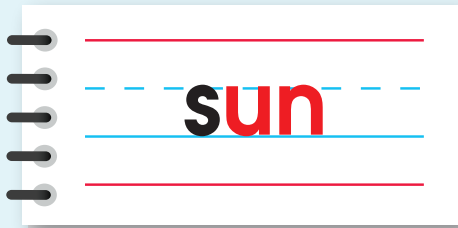

We have fun running under the warm sun



Talk about yourself and your neighbourhood?



I'm Omar , I come from Kuwait , I live in Salmiy

My neighbour Salim lives next to me



SA



Read and answer

1 - Where do you come from?

I come from Kuwait

2 - Where do you live?

I live in Salmia

3 - What is there next to your house?

There is a blue house next to

SA



Write words with the same ending sound



sun



run



clock



dick

I feel







Unit
10
Kuwait
in the past

We will learn:

- Talking about the past.
- Asking and answering questions about past events.



Kuwait in the past

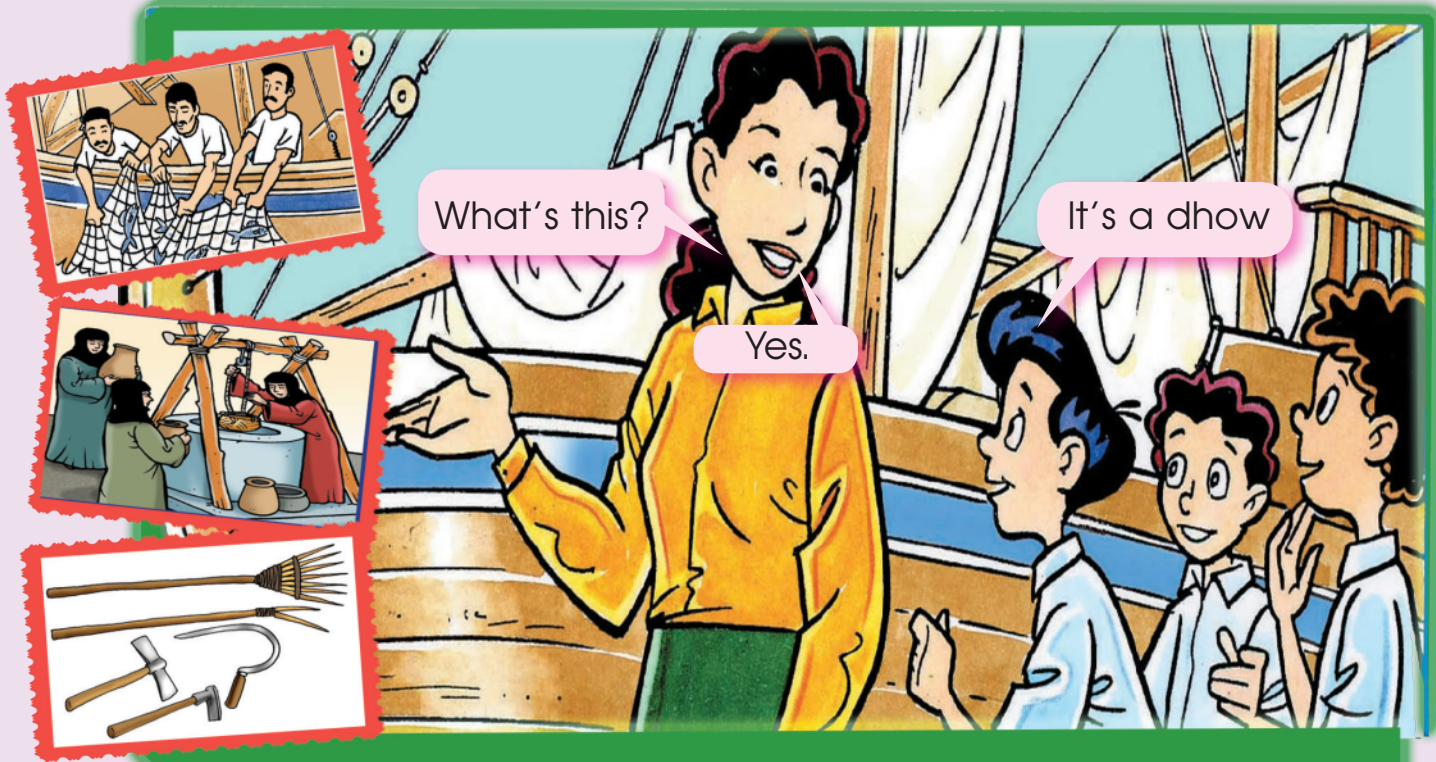

Listen and read

Ali and his friends went on a school trip to the Scientific Center to learn about Kuwait in the past. Ali saw a picture of men fishing and women getting water from the well. Ali's teacher talked about how they used the tools in the past. Ali and his friends had lots of fun.



Where did you go on your school trips?

I went to the museum



Describe the picture / write



I see two men fishing
They have got a lot of fish



Use the verbs to describe actions in the past

My Mother cooked the food



cook



paint

i painted a picture

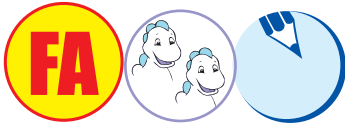

Copy and punctuate

i like kuwait.

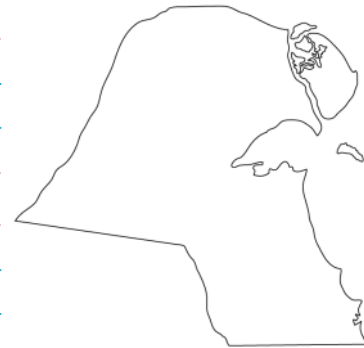



What was there in Kuwait in the past



Look and read

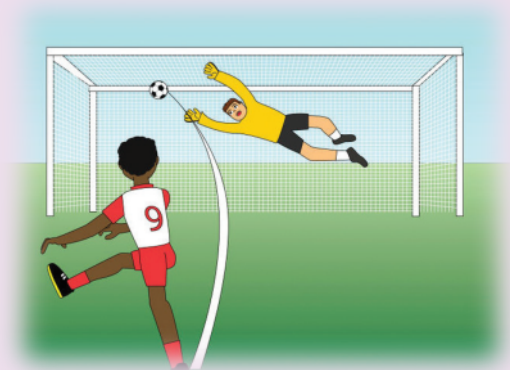

I like **sports** and I like to **score** goals



What did people do in the past?

People worked in fishing
people get water from wells



Find the words that end with the sound /un/ to get out of the maze:

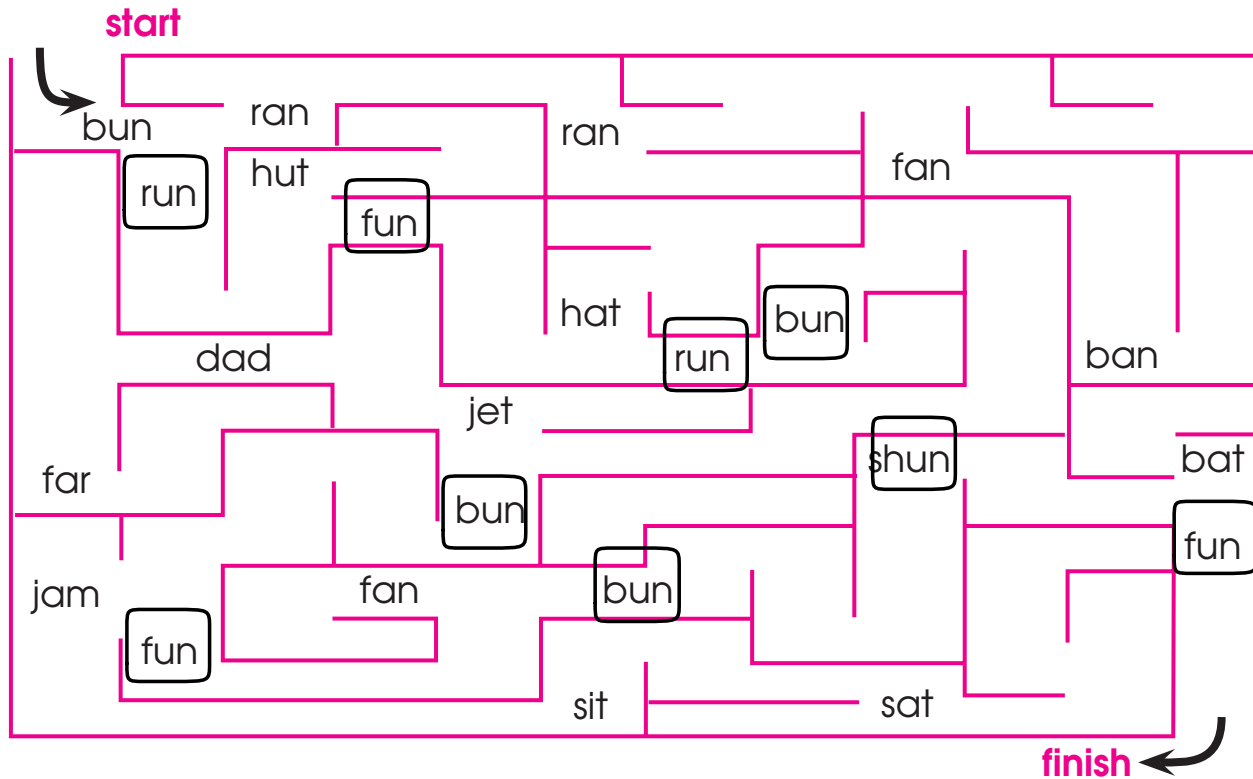

Choose the correct verb

- My grandfather in the past.

- a) fished b) fish

- My mother rice and meat yesterday.

- a) cook b) cooked



Make a poster about Kuwait in the past

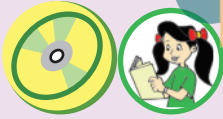

Listen and read

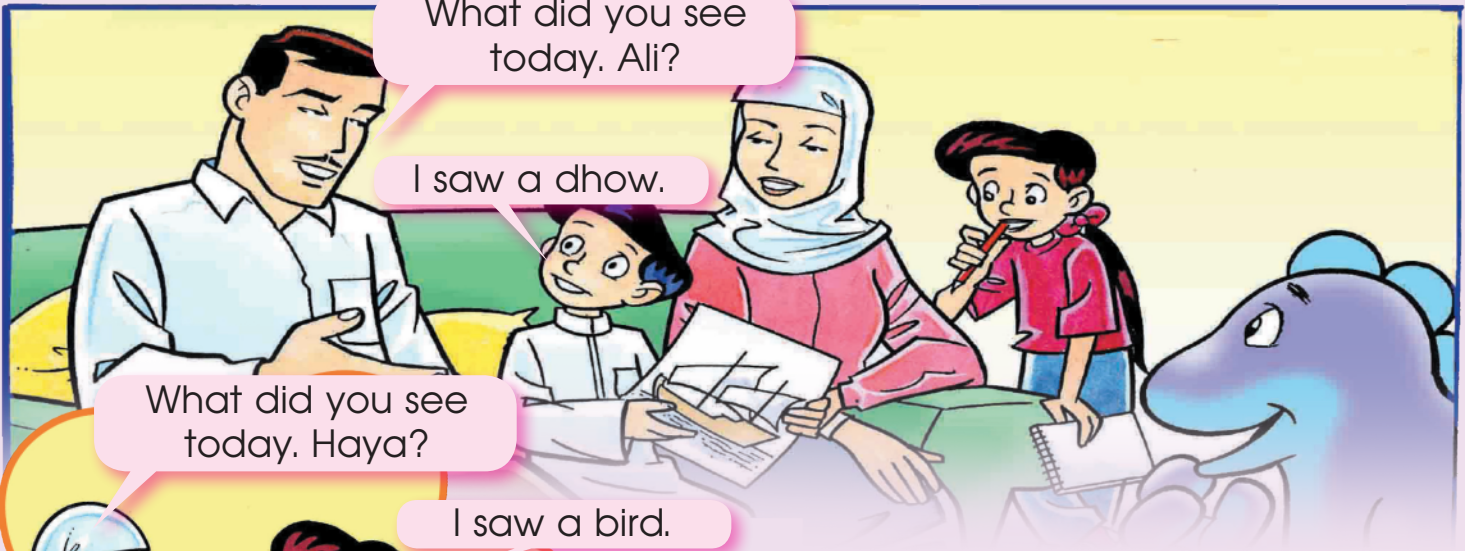

What did you see today, Ali?

I saw a dhow.

What did you see today, Haya?

I saw a bird.



Look and read

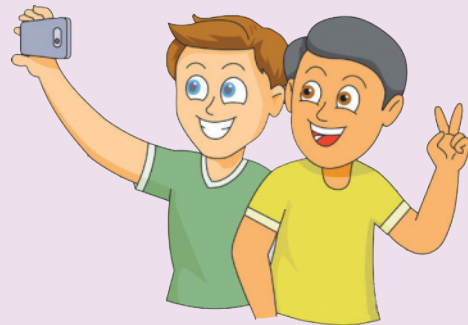

I took a **photo** of an **elephant** with my **phone**



Where did you go yesterday?
What did you see there?



- Read the story.
- Circle the sound /ph/

Phillip loves his sister Phebi. They liked to take photos with their phone. When they went to the zoo they saw a big elephant and a dolphin. They had fun.

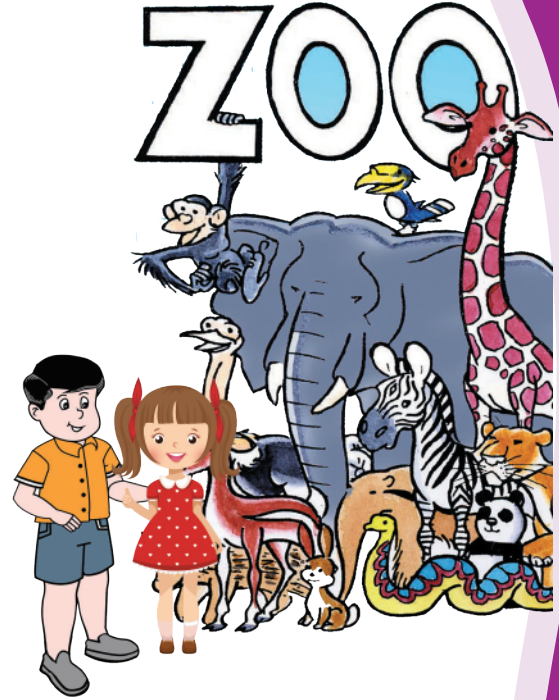

Answer the questions

- Who is Phebi?

She is phillip's sister

- Where did they see the animals?

In the zoo



Tell your friends

- What did you do with your sister/brother last Friday? We went to thw sea

I feel





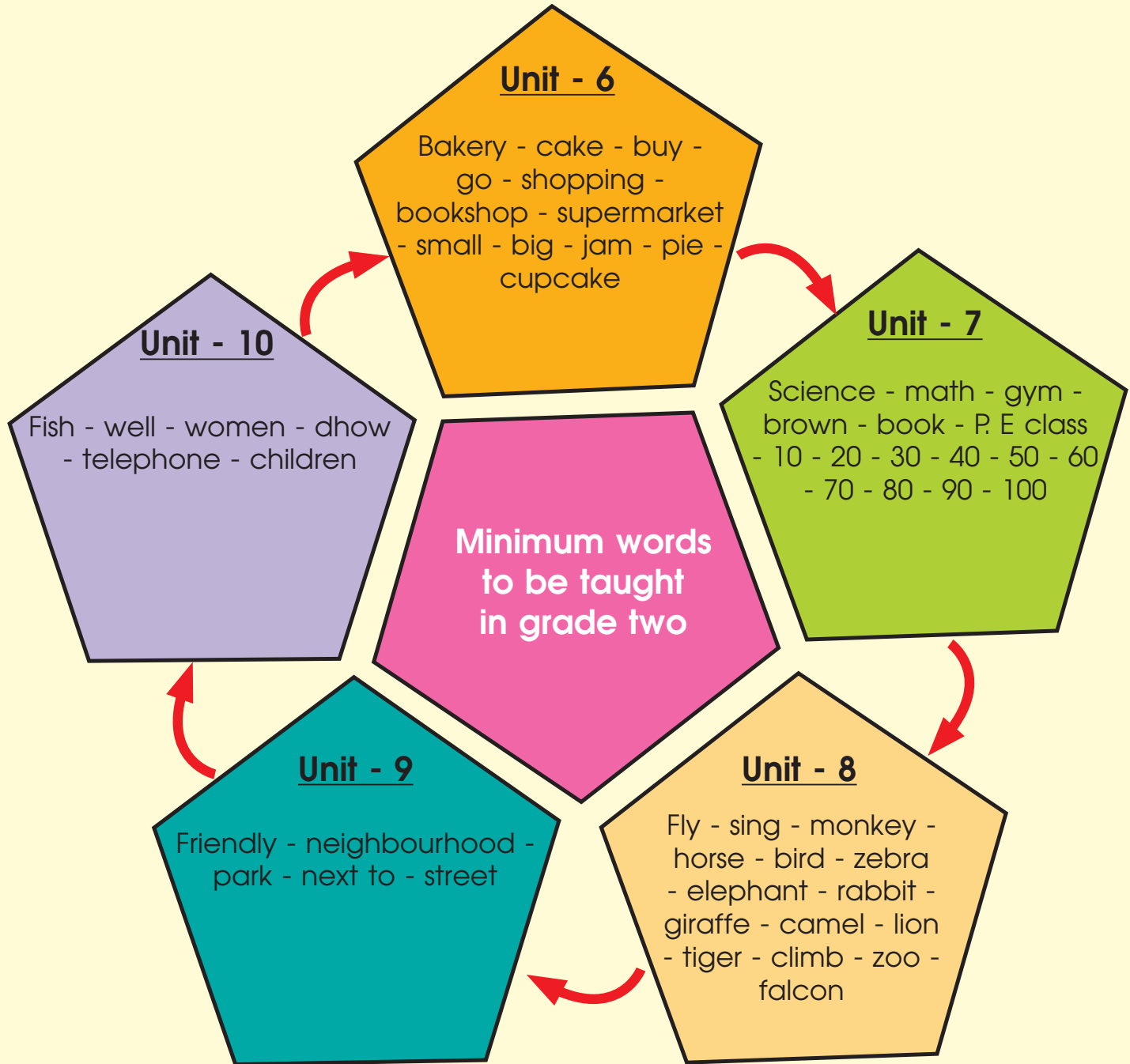



Unit 6



bakery



cake



buy



go shopping



bookshop



supermarket

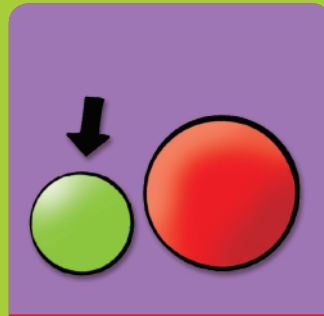

small

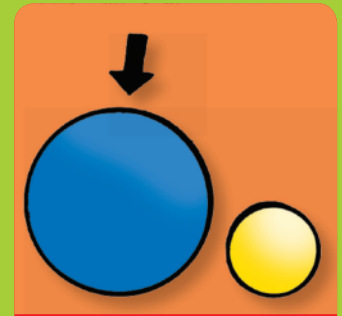

big



jam



pie



cupcake



Unit 7



science

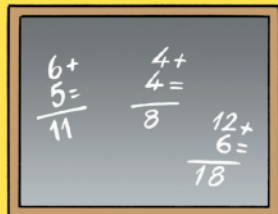

math

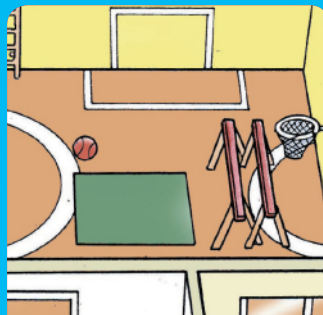

gym



brown



book



P.E class

10

ten

20

twenty

30

thirty

40

forty

50

fifty

60

sixty

70

seventy

80

eighty

90

ninety

100

One hundred



Unit 8



fly



sing



monkey



horse



bird



zebra



elephant

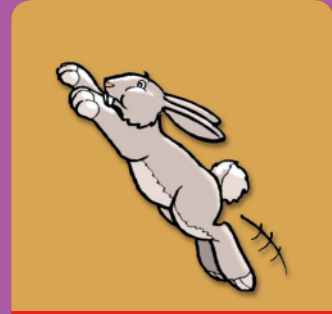

rabbit



giraffe



camel



lion



tiger



climb

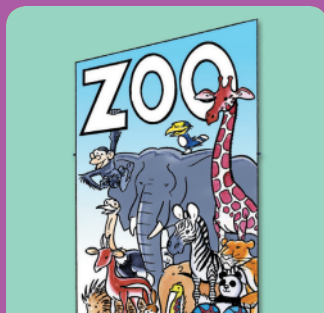

zoo



falcon



Unit 9





Unit 10



fish



well



women

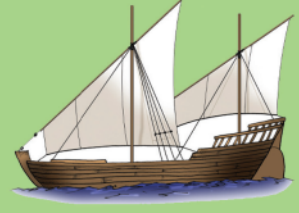

dhow



telephone



children



Song 4: Have we got?

Let's go shopping, Let's buy food
Oh yes, oh yes. That's good.
Have you got any butter?
Have you got any tea?
Have you got any coffee?
buy some please.

Let's go shopping, Let's buy food
Oh yes, oh yes. That's good.
Have you got any chicken?
Have you got any cheese?
Have you got any apples?
buy some please.

Let's go shopping, Let's buy food
Oh yes, oh yes. That's good.
Have you got any biscuits?
Have you got any peas?
Have you got any bananas?
buy some please.

Let's go shopping, Let's buy food
Oh yes, oh yes. That's good.



Song 5

What did you paint at school today?

What did you paint at school today?
I painted a car and a fish and a house.

What did you paint at school today?
I painted a dog and a boy and a mouse.

What colour did you paint the car?
I painted it green, black, and blue.

What colour did you paint the mouse?
I painted it white, and grey too.

What did you paint at school today?
I painted a and a and a

What did you paint at school today?
I painted a and a and a



Song 6 Kuwait is our country

Kuwait is my country, Kuwait is my land.
I love my country its sea and its sand.

Kuwait is our country, we also happy here
We love its trees and flowers. To us it is dear.

Kuwait is our country, Kuwait is our joy
We love our country, every girl and boy





E-Learning

Vocabulary

www.pearsonlongman.com/young_learners/teachers

www.britishcouncil.org/kids.htm

Grammar

www.esl-lounge.com/student/grammar-exercises-elementary.php

www.esl-galaxy.com

www.c4esl.org

Phonics

www.mes-english.com/phonics

www.bbc.co.uk/schools/wordsandpictures/Index.shtml

www.teachchildrenesl.com

www.ictclubs.com/englishzones/phonicszone/ENS-zone2.asp

www.phonicsplay.co.uk

www.familylearning.org.uk/phonics_games.html

www.jamesabela.co.uk/beginner

www.englishraven.com/phonics.html

مدرستي
الكويتية
school-kw.com

